

SALES DRAWING SALES DRAWING

SALES DRAWING SALES DRAWING

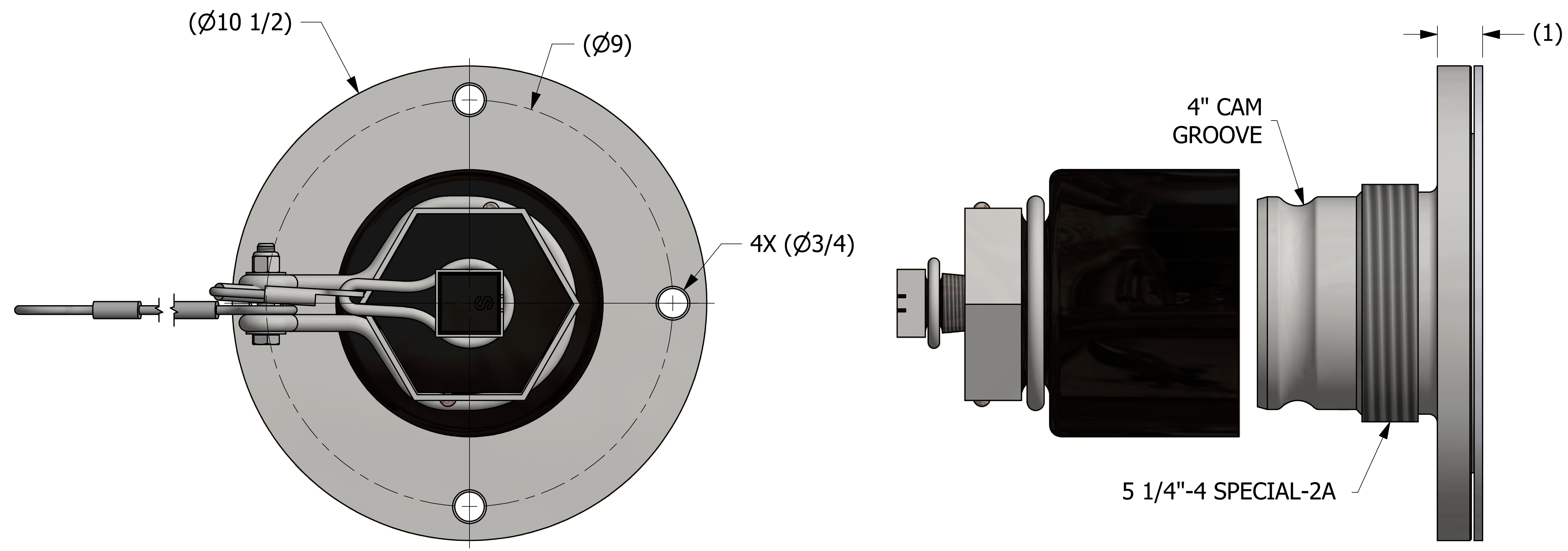

- NOTES:
1. APPROXIMATE HEIGHT = 8"
  2. GASKETS ARE BLACK VITON A.
  3. FITS JAMESBURY 6" WAFER SPHERE VALVE (9.00" B.C.).

THIS PRINT, PROPERTY OF SALCO PRODUCTS INC. CONTAINS PROPRIETARY INFORMATION AND MUST NOT BE COPIED, REPRODUCED, OR USED DETRIMENTALLY TO OUR INTEREST.

UNLESS OTHERWISE SPECIFIED DIMENSIONAL TOLERANCES	DRAWN BY:	CHL
FRACTIONAL: ±1/16	CHECKED BY:	PJG
X.XX: ±.03	PROTOTYPE BY:	CHL
X.XXX: ±.015	PROTOTYPE DATE:	8/17/2007
ANGULAR: ±1°	APPROVED FOR PRODUCTION BY:	PJG
DEBURR ALL SHARP EDGES. ALL MACHINED SURFACES TO HAVE A 125 RMS FINISH UNLESS NOTED OTHERWISE.	PRODUCTION DATE:	1/4/2008
THIRD ANGLE PROJECTION		

B	WEB	5-11-16	E-149523 WAS E-049013, E-119003 WAS E-019022
A	CHL	1-4-08	A-A-59326D WAS MIL-C-27487G, UPDATED TITLEBLOCK
REV	BY	DATE	DESCRIPTION
<b>SALCO PRODUCTS, INC.</b>			
PART NAME: <b>QUICK CONNECT 4" FLANGED</b>			
MATERIAL: <b>316 SS/NYLON</b>			
PROJECT #: <b>WAG0458</b>		SHEET #: <b>1 OF 1</b>	SCALE: <b>1:1</b>
DRAWING #: <b>D23984</b>		PART #: <b>TE4NYITUF06A</b>	